

REVISIONS			
REV.	DESCRIPTION	BY	DATE
A	INITIAL RELEASE	JJ	10/4/2010

THIS OPTION TO BE USED WITH ALL 23 SERIES SPIN PROCESSORS EXCEPT INDECKS

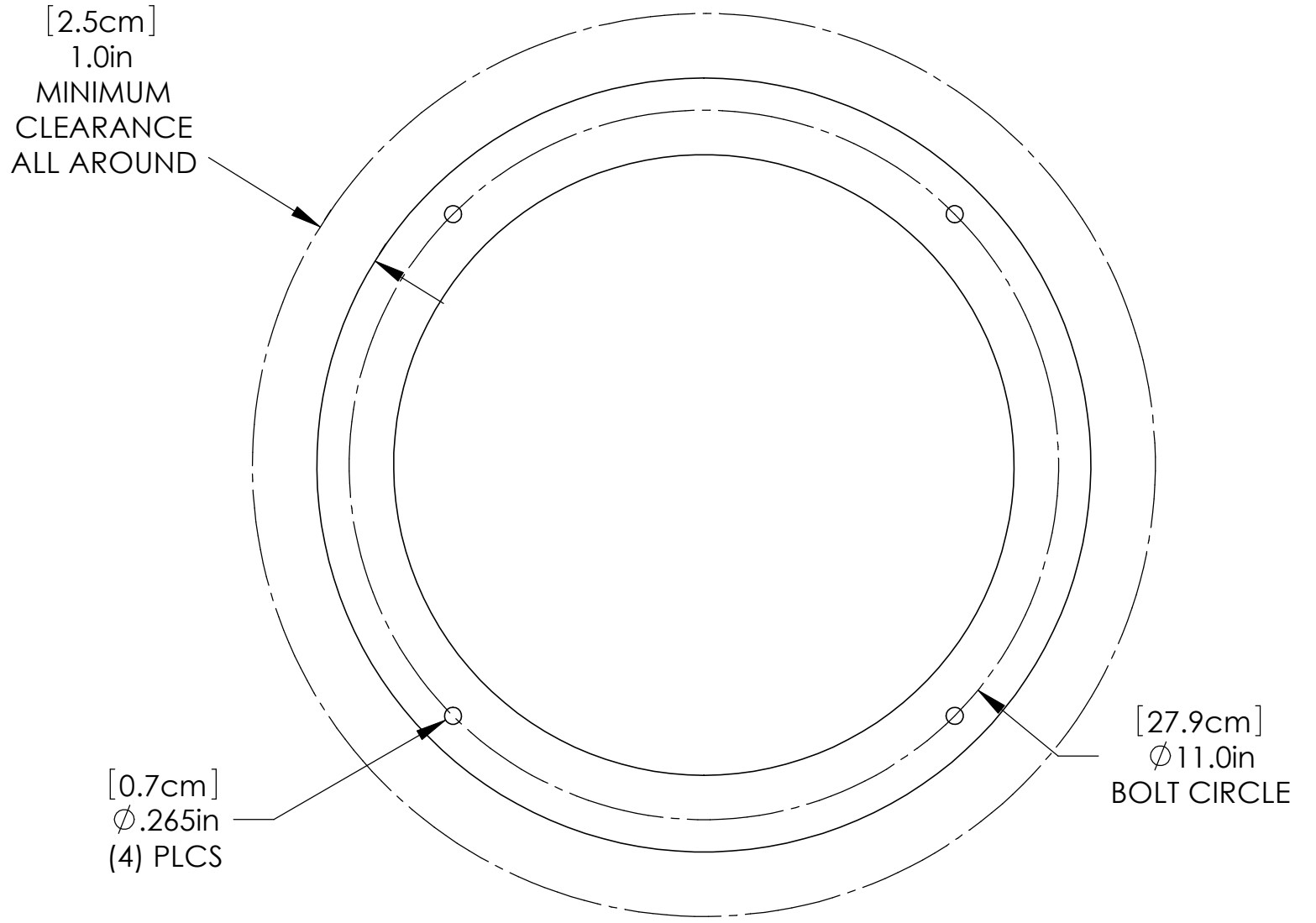
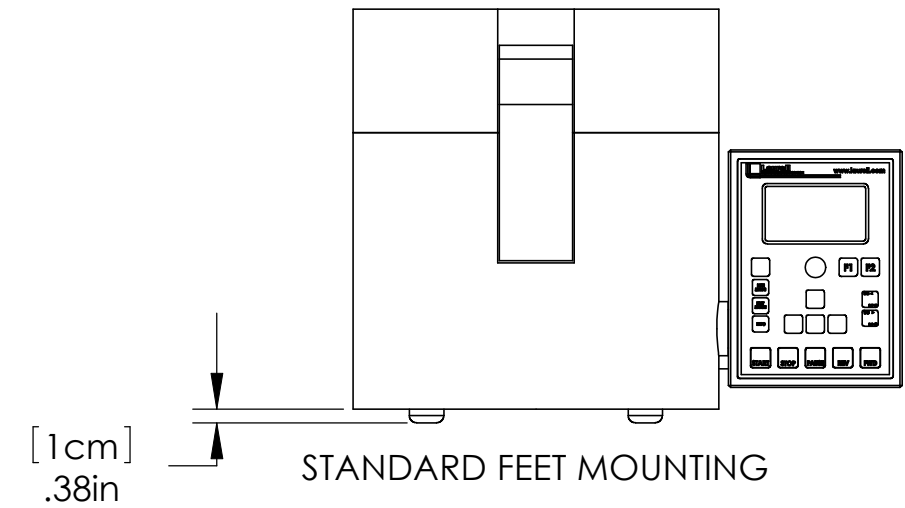
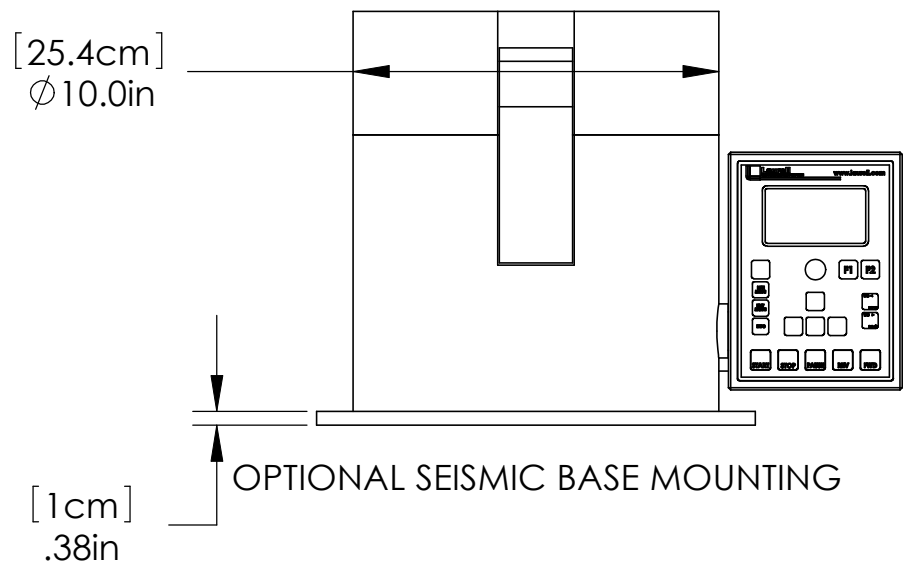
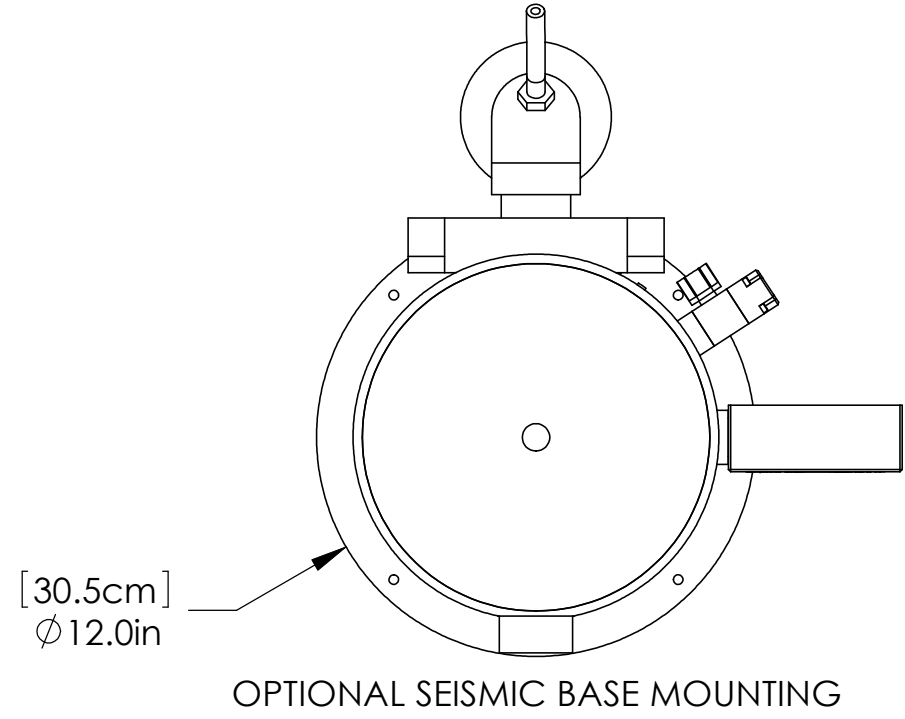

PROPRIETARY AND CONFIDENTIAL
THE INFORMATION CONTAINED IN THIS DRAWING IS THE SOLE PROPERTY OF LAURELL TECHNOLOGIES. ANY REPRODUCTION IN PART OR AS A WHOLE WITHOUT THE WRITTEN PERMISSION OF LAURELL TECHNOLOGIES IS PROHIBITED.

UNLESS OTHERWISE SPECIFIED:		NAME	DATE		
DIMENSIONS ARE IN INCHES		DRAWN	JJ		10/4/10
TOLERANCES:		CHECKED			
FRACTIONAL ±.015		ENG APPR.			
ANGULAR: MACH ± 1/2°		MFG APPR.			
TWO PLACE DECIMAL ±.01		Q.A.			
THREE PLACE DECIMAL ±.005		COMMENTS:	ALL PARTS MUST BE CLEAN AND FREE OF BURRS. BREAK ALL SHARP EDGES, .015" RADIUS MAX.		
INTERPRET GEOMETRIC TOLERANCING PER:		TITLE: OPTION DIMENSIONAL DRAWING, 23 SEISMIC BASE			
MATERIAL		SIZE	DWG. NO.	REV	
FINISH		B	10077399	A	
NEXT ASSY	USED ON	SCALE: 1:8		WEIGHT:	
APPLICATION	DO NOT SCALE DRAWING	SHEET 1 OF 1			